

WingLine L

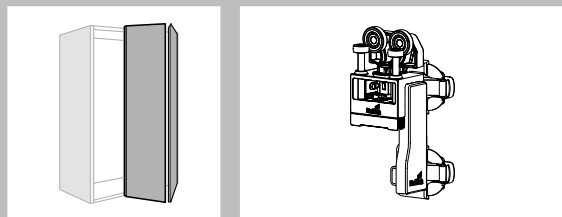

de Montageanleitung

Beschlagsset für obenlaufendes Falttürsystem, leicht, 12 kg, rechts

cz Montážní návod

Sada kování pro skládané dveře s horním nosným profilem, lehký, 12 kg, žeje

dk Monteringsvejledning

Beslagsæt til foroven kørende foldelågesystemer, let, 12 kg, højre

en Installation instructions

Hardware set for top running folding door system, light, 12 kg, right

es Instrucciones de montaje

Juego de herrajes para sistema de puerta plegable deslizamiento ligero, medio, 12 kg, bien

fi Asennusohje

Rautasarjajyhäällä kulkevat taiteovijärjestelmät, kevyt, 12 kg, oikein

fr Instructions de montage

Kit de quincaillerie pour système de portes pliantes coulissant par le haut, léger, 12 kg, droite

it Istruzioni di montaggio

Sistemi kit per ante a libro su binario superiore, leggero, 12 kg, giusto

nl Montagehandleiding

Beslagset voor bovenaanlopend vouwdeursysteem, licht, 12 kg, rechts

pl Instrukcja montażu

Zestaw okuć do systemu do drzwi składanych z górnym mechanizmem jezdnym, jezdny, 12 kg, prawidłowy

ru Инструкция по монтажу

Комплект фурнитуры для система фурнитуры для складных дверей с верхним ходовым элементом, легкий, 12 кг, верно

se Monteringsanvisning

Beslagssats för topplöpande vikkörssystem, lätt, 12 kg, höger

tr Montaj kılavuzu

Üstten hareketli katlanır kapak sistemi için donanım set, hafif, 12 kg, sağ

kr 설치 설명서

상부 러닝 슬라이딩 도어 시스템, 가벼운, 12kg, 오른쪽

jp 金具取付けマニュアル

上吊りタイプ引折れ戸扉システム、軽い、12kg、右

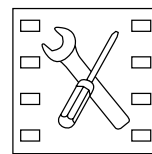

<https://www.hettich.com/short/yezojgx>

de Kurzanleitung zur Montage (Video als Download)

cz Krátký návod k montáži (video ke stažení)

dk Kort vejledning i monteringen (video til download)

en Short installation guide (video for downloading)

es Guía de montaje (video para descargar)

fi Asennuksen pikaohje (ladattava video)

fr Instructions de montage succinctes (vidéo à télécharger)

it Istruzioni di montaggio (Video disponibile per il download)

nl Korte handleiding voor de montage (video om te downloaden)

pl Skróconajstrakcja montażu (film do pobrania)

ru Краткая инструкция по монтажу (видео, доступное для загрузки)

se Kort anvisning för monteringen (video att ladda ner)

tr Montaj için kısatimat (indirilebilir video)

kr 조립에 대한 빠른 지침 (비디오 다운로드)

jp 組み立てのための簡単な説明書 (ビデオをダウンロード)



2 - 4



5



6



7 - 8



a



9 - 12



b



c



13 - 16



17 - 18



18 - 19



de	Produkt Sets	Informationen	Montage	Demontage	Planung	Verstellung
cz	Sady výrobků	Informace	Montáž	Demontáž	Navrhování	Seřizování
dk	Produkt Sæt	Informationer	Montering	Afmontering	Planlægning	Justering
en	Product sets	Information	Installation	Removal	Planning	Adjustment
es	Sets de producto	Información	Montaje	Desmontaje	Planificación	Ajuste
fi	Tuote setti	Tietoja	Asennus	Purkaminen	Suunnittelu	Säätää
fr	Produit kits	Informations	Montage	Démontage	Planification	Réglage
it	Kit prodotto	Informazioni	Montaggio	Smontaggio	Progettazione	Regolazione
nl	Product sets	Informatie	Montage	Demontage	Planning	Verstelling
pl	Zestawy produktów	Informacje	Montaż	Demontaż	Planowanie	Regulacja
ru	Комплект	Информация	Монтаж	Демонтаж	Проектирование	Регулировка
se	Produktset	Information	Montering	Demontering	Planering	Justering
tr	Ürün setleri	Bilgiler	Montaj	Demontaj	Planlama	Ayarlama
kr	取外し	インフォメーション	取り付け	取外し	プランニング	調整
jp	제품 세트	정보	설치	해체	계획	조절

de **WICHTIG!**
VOR GEBRAUCH SORGFÄLTIG LESEN
AUFBEWAHREN FÜR SPÄTERESNACHSCHLAGEN

cz **DŮLEŽITÉ!**
PŘED POUŽITÍM POZORNĚ PŘEČTĚTE
ULOŽTE PRO POZDĚJŠÍ POTŘEBU

dk **VIGTIGT!**
LÆSESOMHYGGELIGT FØR BRUG
OPBEVARES TIL SENERE BRUG

en **IMPORTANT!**
READ CAREFULLY BEFORE USE
KEEP IN A SAFE PLACE FOR FUTURE REFERENCE

es **¡IMPORTANTE!**
LEER DETENIDAMENTE ANTES DE USAR
GUARDAR EN LUGAR SEGURO PARA FUTURAS CONSULTAS

fi **TÄRKEÄÄ!**
LUE HUOLELLISESTI ENNEN KÄYTTÖÄ
SÄILYTETTÄVÄ TURVAKLISESSA PAIKASSA MYÖHEMPÄÄ
TARVETTA VARTEN

fr **IMPORTANT!**
LIRE ATTENTIVEMENT AVANT UTILISATION
CONSERVER EN LIEU SÛR POUR CONSULTATION ULTÉRIEURE

it **IMPORTANTE!**
LEGGERE ATTENTAMENTE PRIMA DELL'USO
CONSERVARE PER CONSULTARE IN SEGUITO

nl **BELANGRIJK!**
VOOR GEBRUIK ZORGVULDIG LEZEN
BEWAAREN ALS NASLAGWERK

pl **WAŻNE!**
PRZED UŻYCIEM NALEŻY DOKŁADNIE PRZECZYTAĆ
ZACHOWAĆ DO WYKORZYSTANIA W PRZYSZŁOŚCI

ru **ВАЖНО!**
ВНИМАТЕЛЬНО ИЗУЧИТЕ ИНФОРМАЦИЮ ПЕРЕД
ИСПОЛЬЗОВАНИЕМ
ХРАНИТЕ В БЕЗОПАСНОМ МЕСТЕ ДЛЯ БУДУЩЕГО
ИСПОЛЬЗОВАНИЯ

se **VIKTIGT!**
LÄS NOGGRANTINNAN ANVÄNDNING
FÖRVARA UNDER UPSIKT

tr **ÖNEMLİ!**
KULLANMADAN ÖNCE DİKKATLİCE OKUYUNUZ
DAHA SONRAKİ KULLANIM İÇİN SAKLAYINIZ

kr **중요성!**
사용전 주의깊게 읽어주세요
안전한 장소에 보관해주세요

jp **重要事項**
ご使用前に必ずご確認ください
本書は必要なときにすぐに取り出せるよう、大切に
てください。



de
Bestimmungsgemäße Verwendung
Der Möbelbeschlag WingLine L wird für obenlaufende Falttürsysteme verwendet.
Erist für die Verwendung in Möbeln nach EN14749 und den Einsatz in geschützten,
trockenen Innenräumen vorgesehen
Eine andere als die unter „Bestimmungsgemäße Verwendung“ festgelegte Verwendung
gilt als nicht bestimmungsgemäß
Der Beschlag ist getestet nach EN15706, Level 3
Es wird empfohlen, den Schrank gegen Kippen zu sichern

cz
Použití v souladu s určením
Nábytkové kování WingLine L se používá pro kování pro skládané dveře s horním nosným
profilem.
Je určeno do nábytku podle EN14749 a pro použití v chráněných a suchých interiérech.
Jiné použití, než které je definované pod bodem „Použití v souladu s určením“, se považuje za
nesprávné.
Kování je testováno podle EN15706, úroveň 3.
Doporučuje se zajistit skříň proti překlopení.

dk
Tilsigtet brug
Møbelbeslaget WingLine L anvendes til foroven kørende foldelågesystemer.
Det er beregnet til anvendelse i møbler i overensstemmelse med EN14749 og til brug i
beskyttede, tørre indendørs lokaler.
Anden brug end den, der er fastlagt under „Tilsigtet brug“, betragtes som utilsigtet brug.
Beslaget er testet iht. EN15706, level 3.
Det anbefales at sikre skabet mod at vælte.

en
Intended Use
The WingLine L furniture fitting is used for top running folding door systems.
It is intended for application in furniture to EN14749 and use in dry indoor environments
where it is protected from the elements.
Any use other than that defined under „Intended Use“ will be deemed to be non-inten-
ded use.
The fitting is tested to EN15706, Level 3.
It is recommended to prevent the cabinet from toppling over.

es
Utilización conforme al uso previsto
El herraje de mueble WingLine L se utiliza para sistema de puerta plegable deslizamiento
superior.
Está previsto para el uso en muebles según EN14749 y su aplicación en estancias
protegidas y secas.
Cualquier otra utilización que difiera de la „Utilización conforme al uso previsto“ se
considera no conforme a lo previsto.
El herraje ha sido verificado conforme a EN15706, nivel 3.
Se recomienda asegurar el armario para evitar que pueda volcar.

fi
Käyttötarkoitus
WingLine L -huonekaluhelaa käytetään ylhäällä kulkevat taiteovijajestelmät.
Se on tarkoitettu käytettäväksi huonekaluissa EN14749 -standardin mukaisesti ja sitä
voidaan käyttää suojatuissa, kuivissa sisätiloissa.
Kaikenlainen muu kuin „käyttötarkoituksen mukainen“ käyttö ei ole käyttötarkoituksen
mukaista käyttöä.
Hela on testattu EN15706 -standardin, taso 3, mukaisesti.
Kaappi kannattaa varmistaa kaatumista vastaan.

fr
Utilisation conforme à la destination prévue
La ferrure de meuble WingLine L est utilisée pour les systèmes de portes pliantes couliss-
sant par le haut.
Elle est prévue pour une utilisation dans des meubles conformément à la norme EN
14749 et, à l'intérieur, dans des pièces non humides et protégées.
Toute utilisation autre que celle indiquée dans l'«utilisation conforme à la destination
prévue» est considérée non-conforme.
La ferrure est testée selon la norme EN15706, niveau 3.
Il est conseillé de sécuriser l'armoire pour éviter qu'elle ne bascule.

it
Uso conforme alla destinazione
Il dispositivo per mobili WingLine L viene utilizzato come sistemi per ante a libro su
binario superiore.
Il suo uso è previsto in mobili conformi alla norma EN14749 e in ambienti interni
protetti e asciutti.
Ogni altro utilizzo diverso da quanto indicato al punto “Uso conforme alla destinazione”

viene considerato non conforme.
Il sistema è testato secondo la EN15706, Level 3.
Si consiglia di fissare il mobile per evitare che si ribalti.

nl
Doelmatig gebruik
Meubelbeslag WingLine L wordt voor bovenaan lopend vouwdeursysteem.
Het is gemaakt voor gebruik in meubels volgens EN14749 en toepassing in beschutte,
droge binnenuimtes.
Elk ander gebruik dan vastgelegd onder „Doelmatig gebruik“ geldt als zijnde niet volgens
de voorschriften.
Het beslag werd getest volgens EN15706, level 3.
Wij adviseren de kast te beveiligen tegen kantelen.

pl
Zastosowanie zgodne z przeznaczeniem
Okucie meblowe WingLine L stosowane jest w systemy do drzwi składanych z górnym
mechanizmem jezdnyh.
Przeznaczone jest do zastosowania w meblach zgodnie z EN14749 oraz do zastosowania w
osłoniętych, suchych pomieszczeniach wewnętrznych.
Zastosowanie inne niż określone jako „Zastosowanie zgodne z przeznaczeniem” jest niezgod-
ne z przeznaczeniem.
Okucie zostało przetestowane zgodnie z EN15706, poziom 3.
Zaleca się zabezpieczyć szafy przed przewróceniem się.

ru
Использование по назначению
Фурнитура WingLine L предназначена для система фурнитуры для складных дверей с
верхним ходовым элементом.
Она предусмотрена для использования в мебели по стандарту EN14749 и для
применения в защищенных, сухих внутренних помещениях.
Иное применение, кроме указанного в разделе „Использование по назначению”,
считается использованием не по назначению.
Фурнитура испытана по стандарту EN15706, уровень 3.
Рекомендуется принять меры против опрокидывания шкафа.

se
Ändamålsenlig användning
Möbelbeslaget WingLine L används för topplöpande skjutdörssystem.
Det är tillverkat för att användas i möbler enligt EN14749, i skyddade, torra utrymmen
inomhus.
En annan användning än den som fastställts med „Ändamålsenlig användning”, anses som
icke ändamålsenlig.
Beslaget är testat enligt EN15706, nivå 3.
Det rekommenderas att säkra skåpet mot att väla.

tr
Amacına uygun kullanım
Mobilya aksami WingLine L, üstten hareketli katlanır kapak sistemleri
EN14749 standardına uygun, kuru ve korunaklı iç mekan mobilyalarında kullanım için
öngörülmüştür.
„Amacına uygun kullanım“ başlığı altında öngörülenin dışındaki bir kullanım, amacına aykırı
olarak nitelendirilir.
Aksam, EN15706, Seviye 3 uyarınca test edilmiştir.
Dolabın, devrilmeye karşı emniyete alınması önerilir.

kr
사용용도
WingLine L은 상부 러닝방식의 슬라이딩 도어 시스템입니다.
EN14749에 따라 인증된 가구용 피팅으로서 손상을
방지하기 위해 건조한 실내에서 사용해야 합니다.
제시된 목적 이외의 용도에는 사용할 수 없습니다.
이 피팅은 EN15706, Level 3에 따라 테스트 완료 하였습니다.
설치시 수납장을 넘어뜨리지 않도록 유의하시기 바랍니다.

jp
用途
トップライン L は吊り戸タイプの引き戸金物です。
上部レールで支える吊り戸タイプです。
通常の屋内（異常な高湿度及び温度ではない環境）に設置される
での使用には
適しません。
この金具はヨーロッパ品質基準 EN15706 のレベル 3 の試験をパスし
ます。
家具本体は転倒せぬよう必ず建築躯体に固定してください。

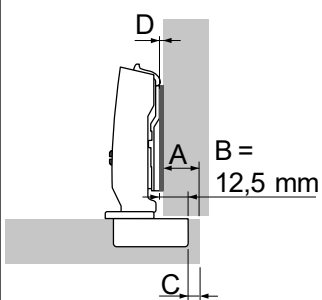
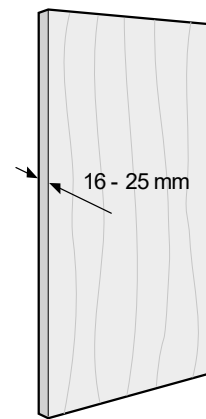
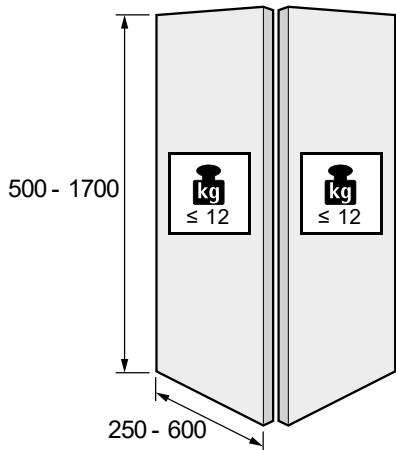

C = 4,0 mm
D = 1,5 mm
A = 15,0 mm

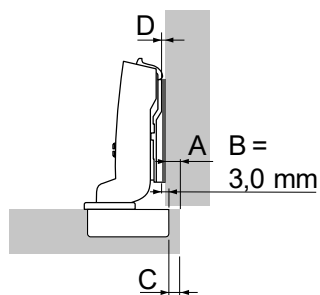

C = 4,0 mm
D = 1,5 mm
A = 5,5 mm

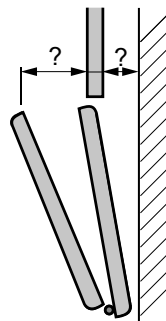
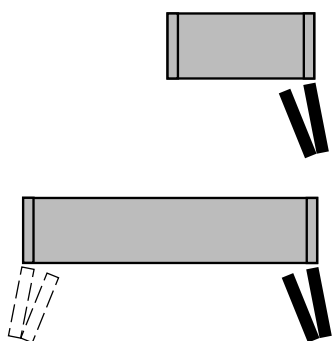
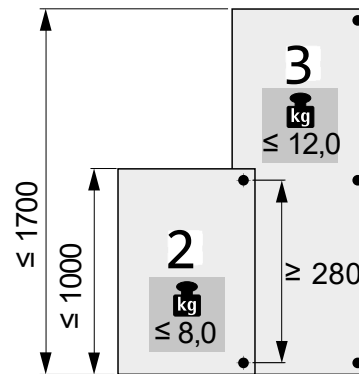
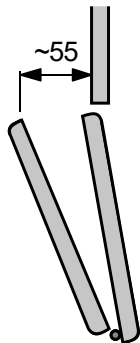
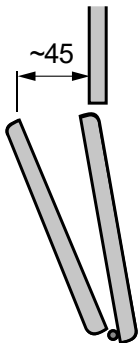

<https://www.hettich.com/short/gj6kvb7>

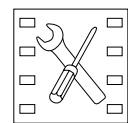

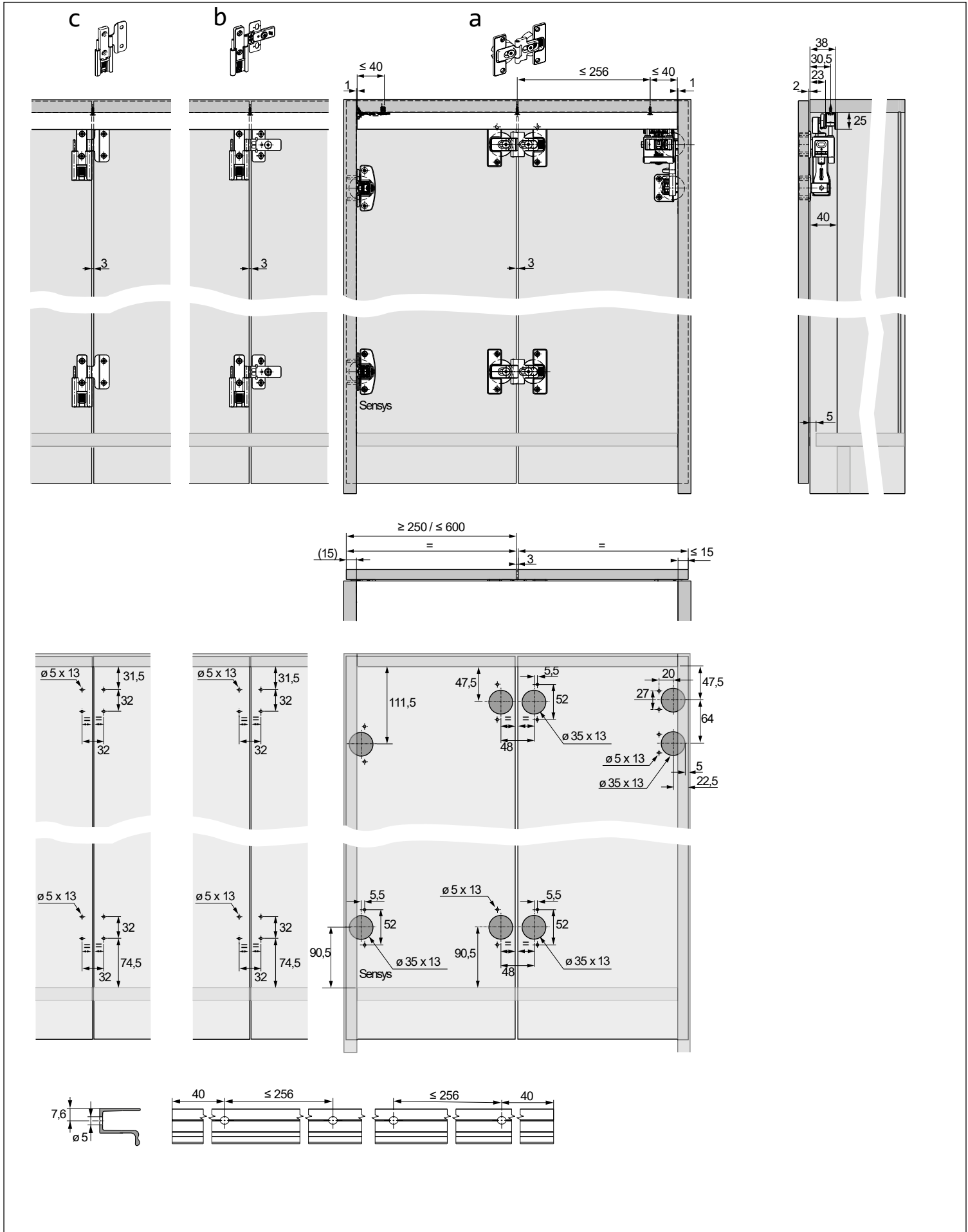

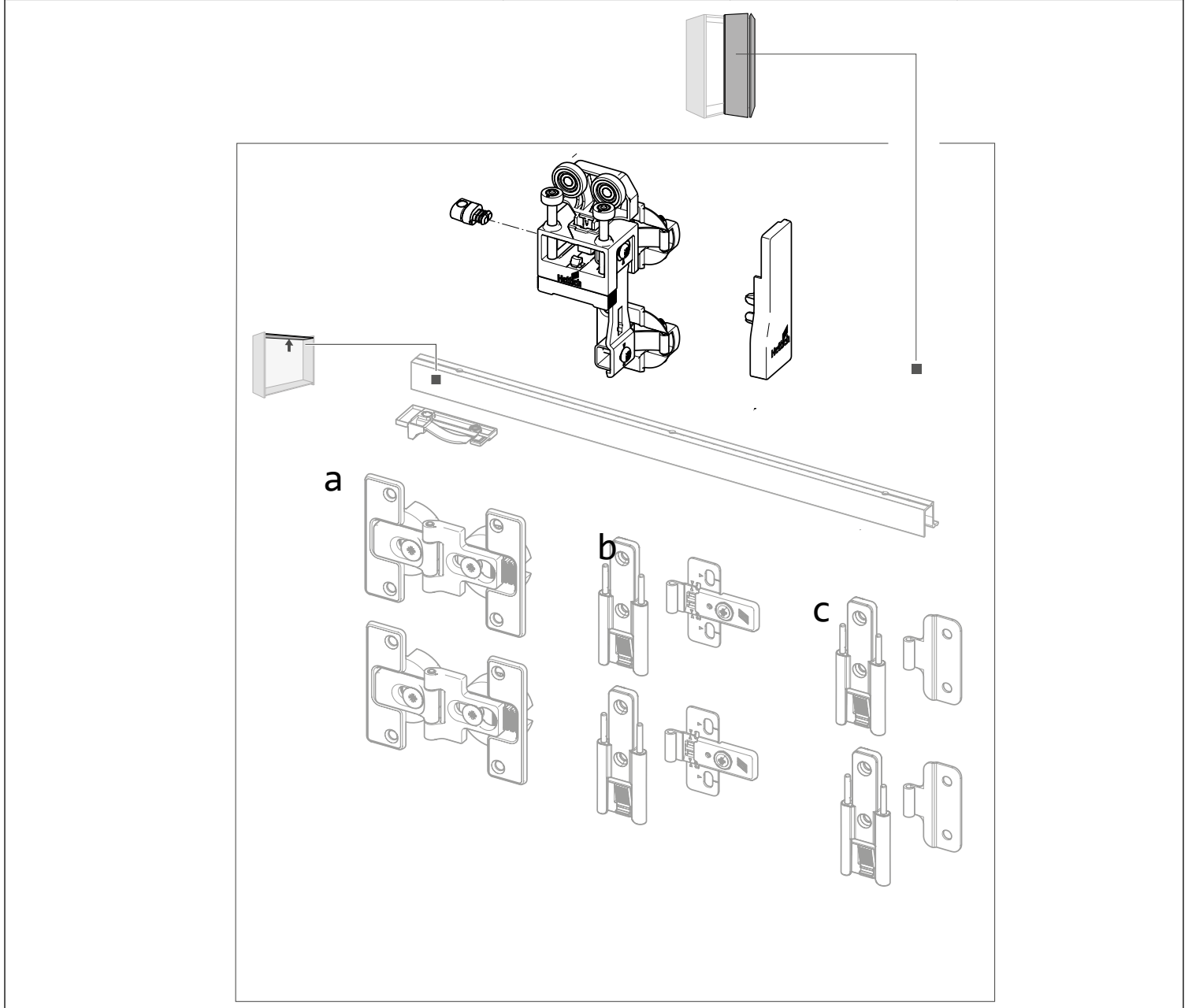
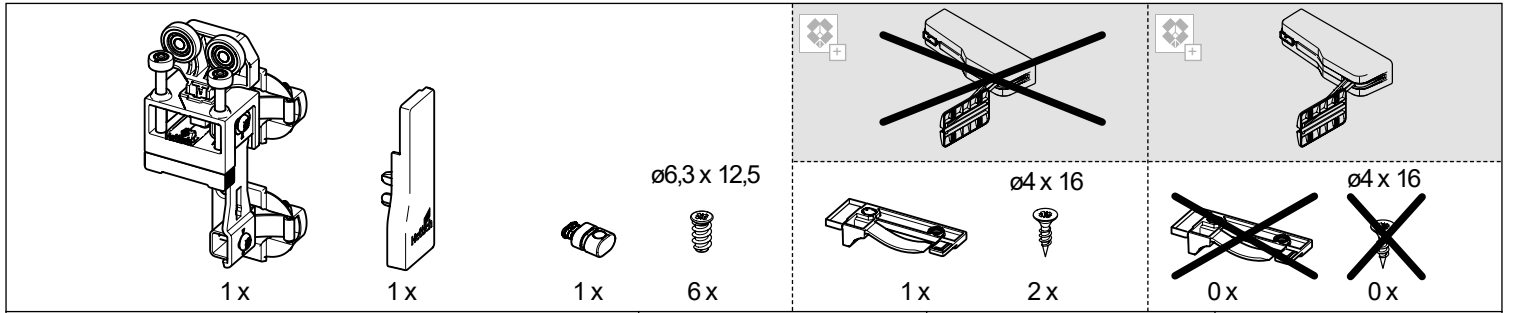

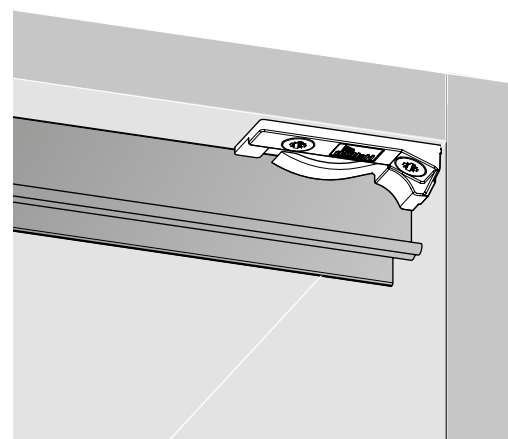
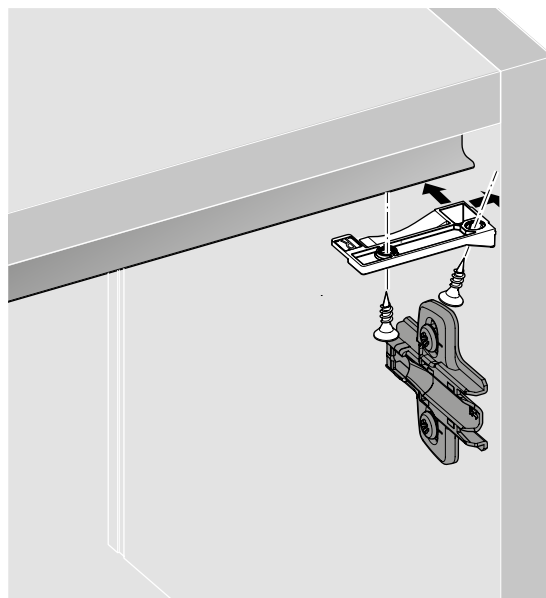
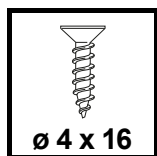
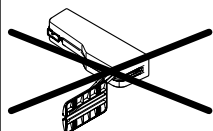
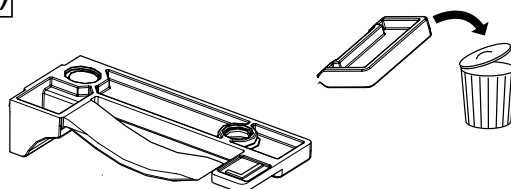
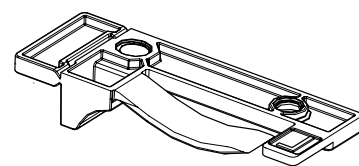
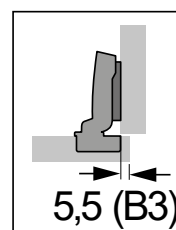
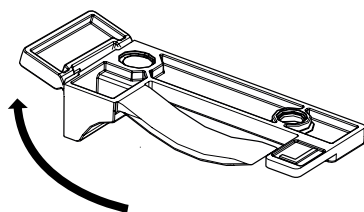
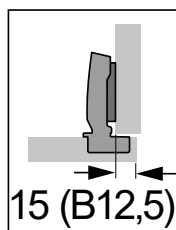
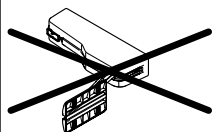
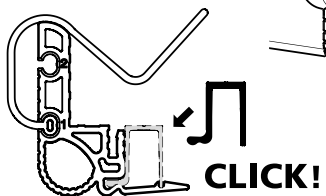
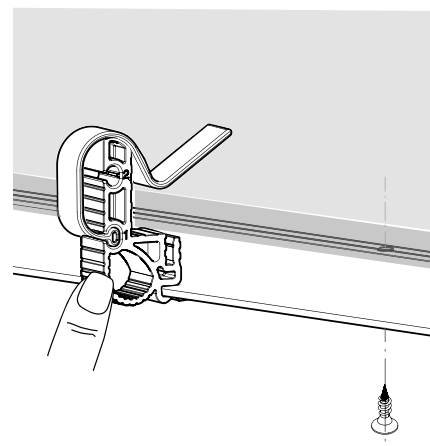
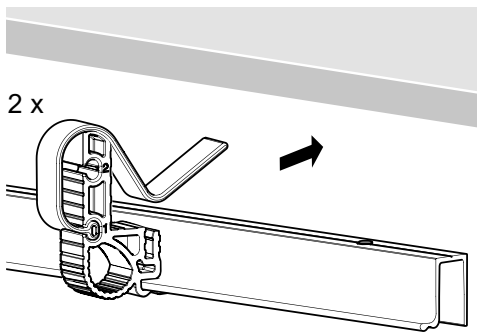
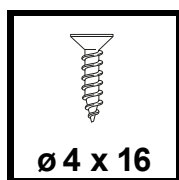
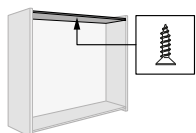
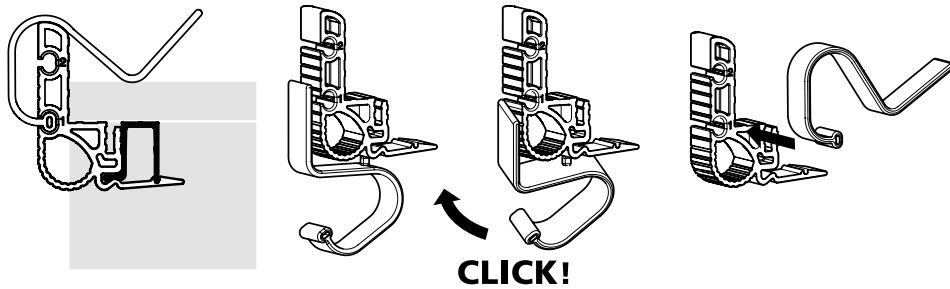

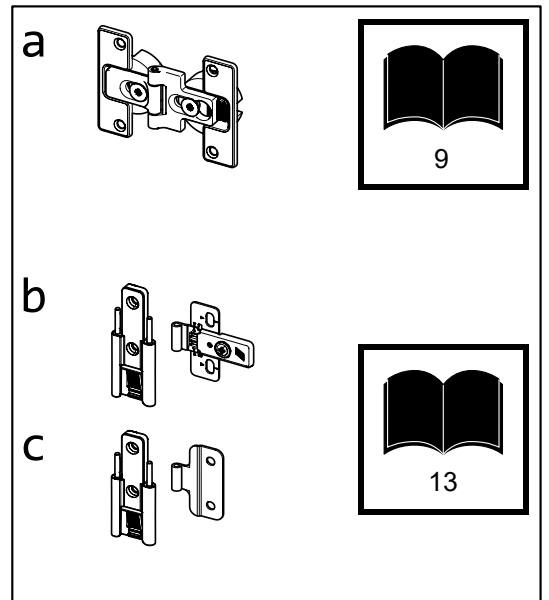
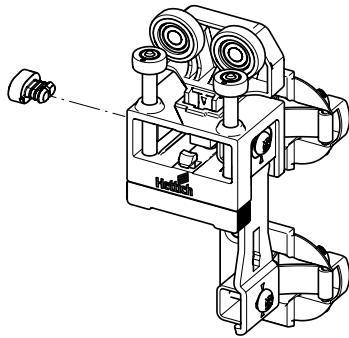
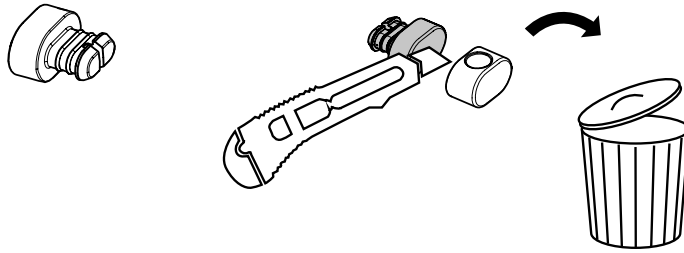
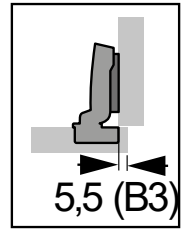
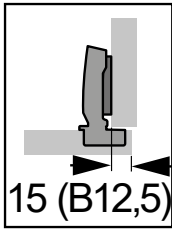



a

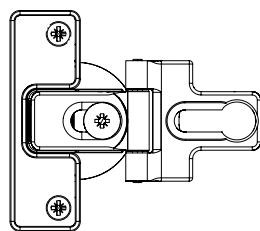
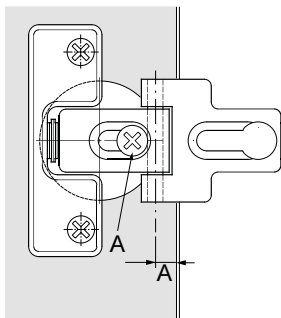
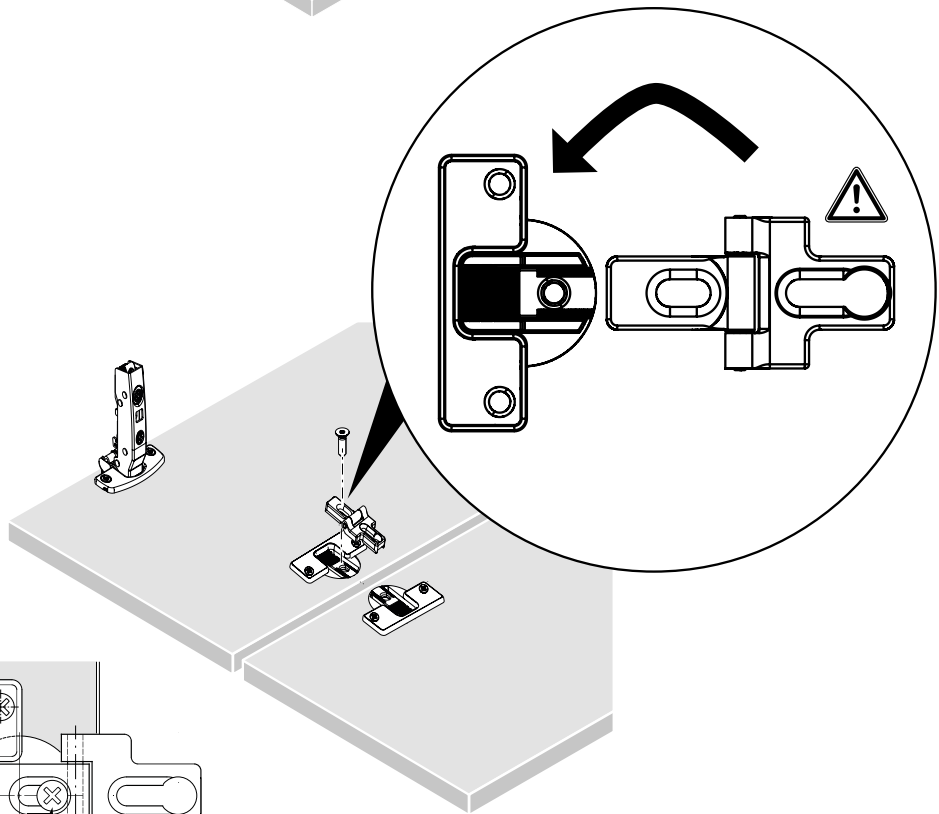
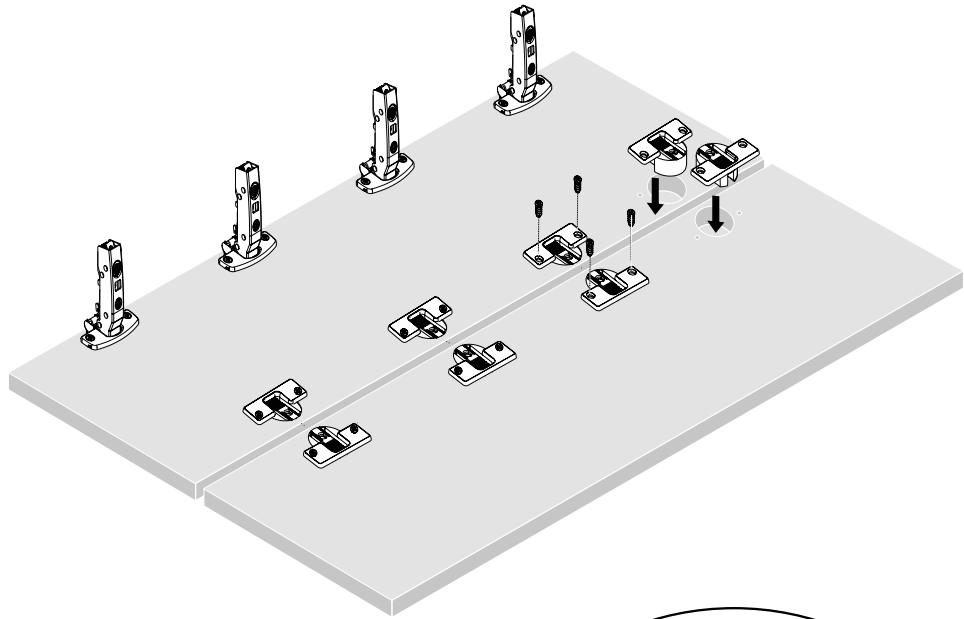
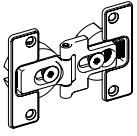

A = 6

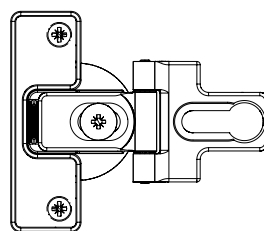

A = 3

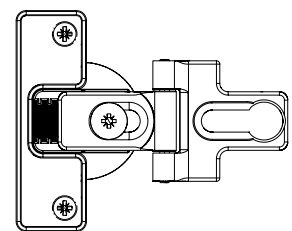

A = 0



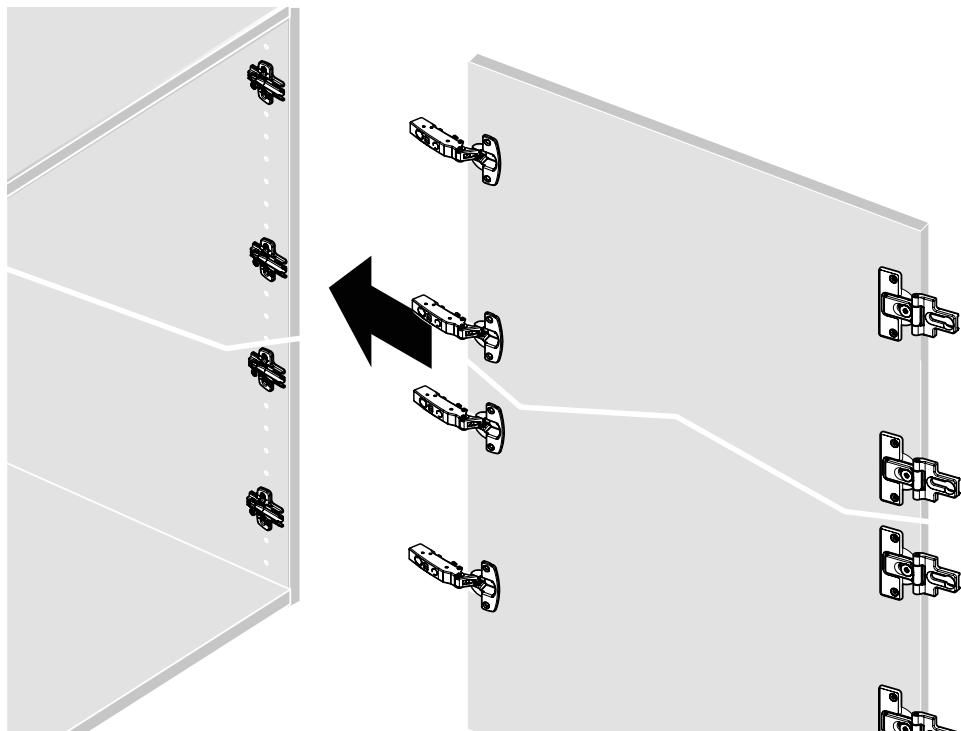
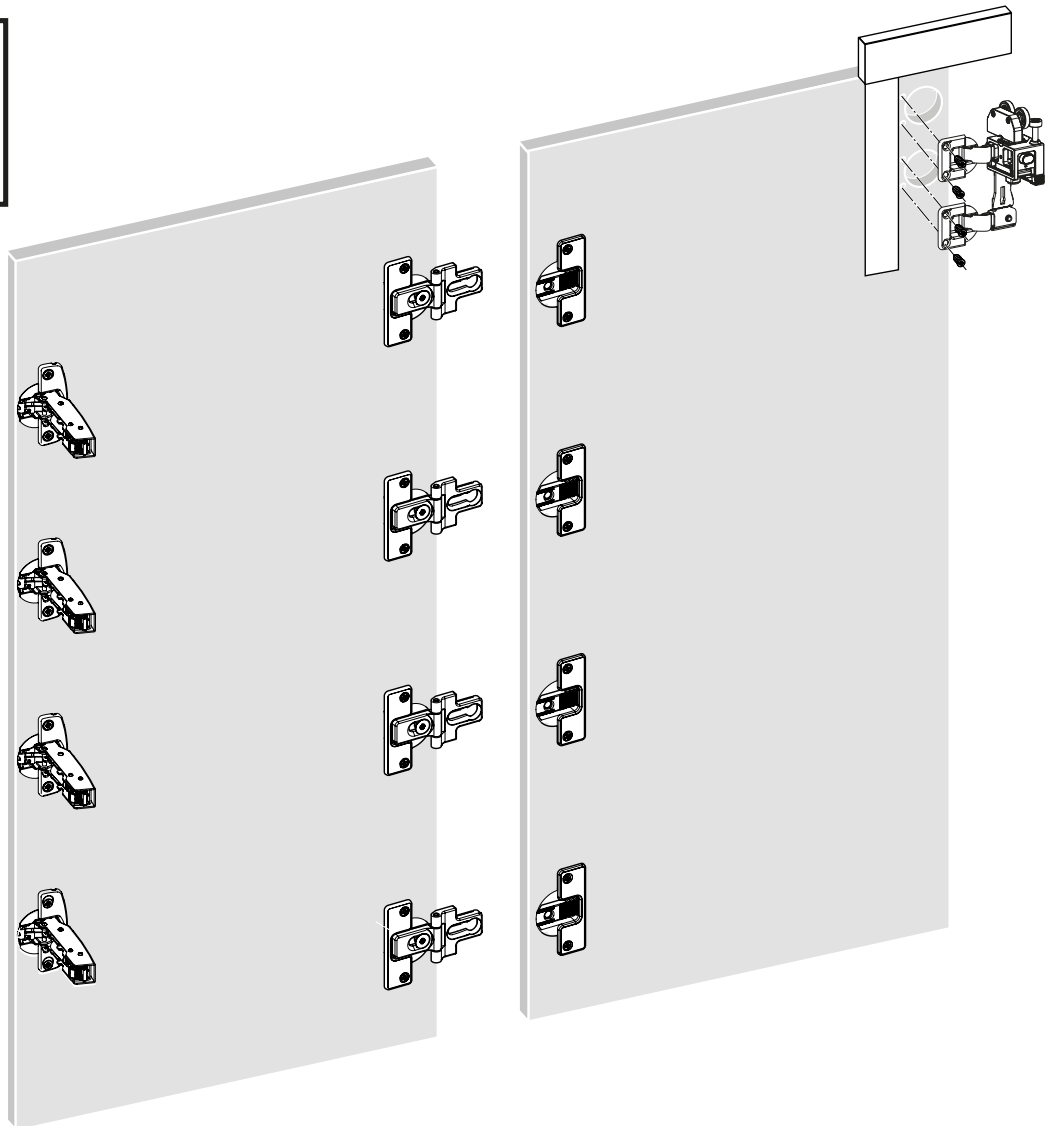
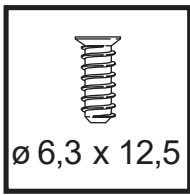

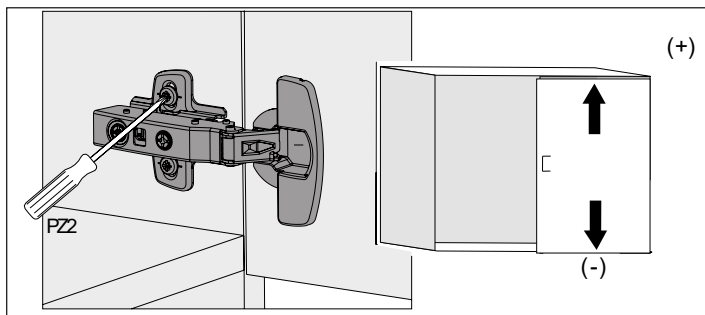
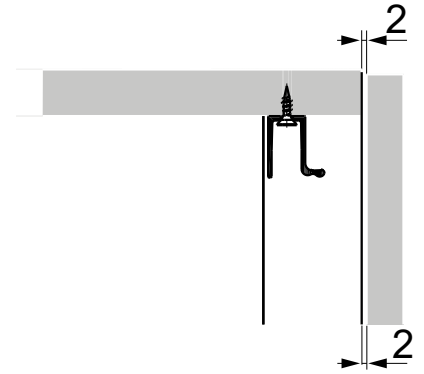
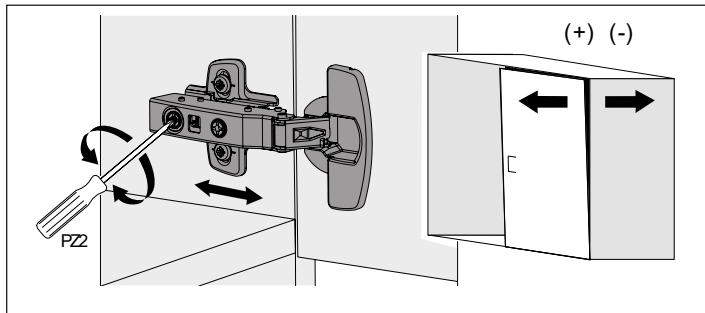
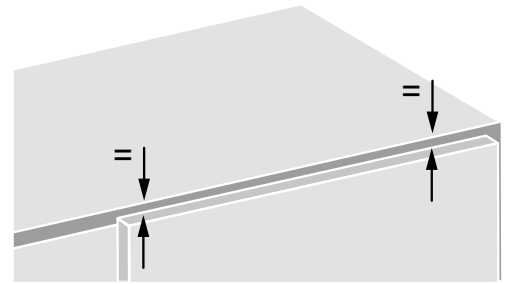
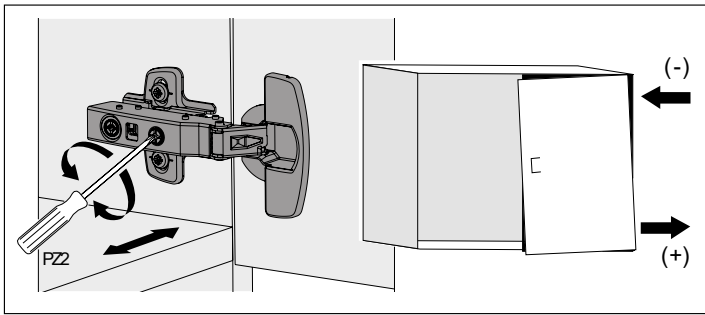

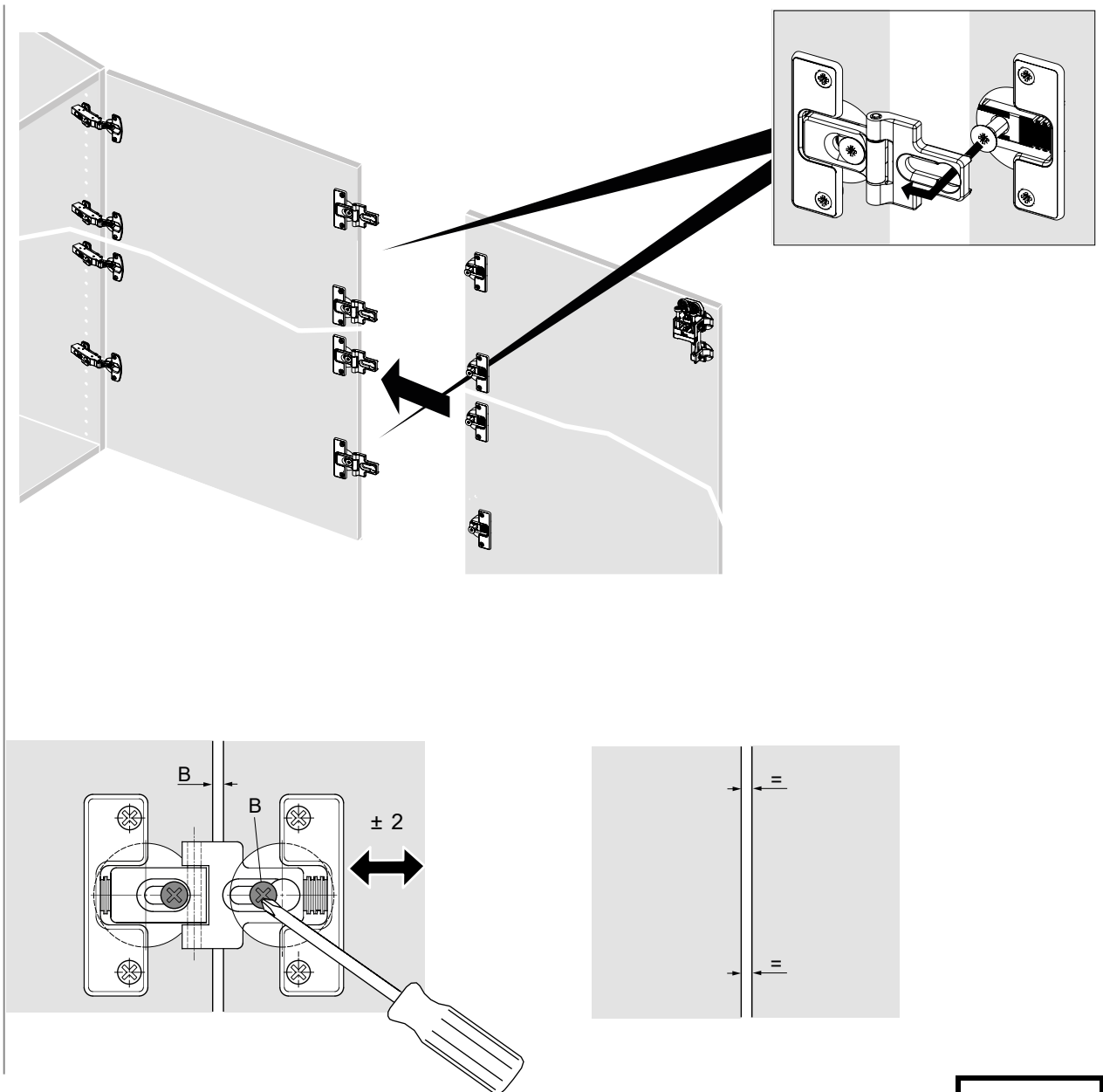

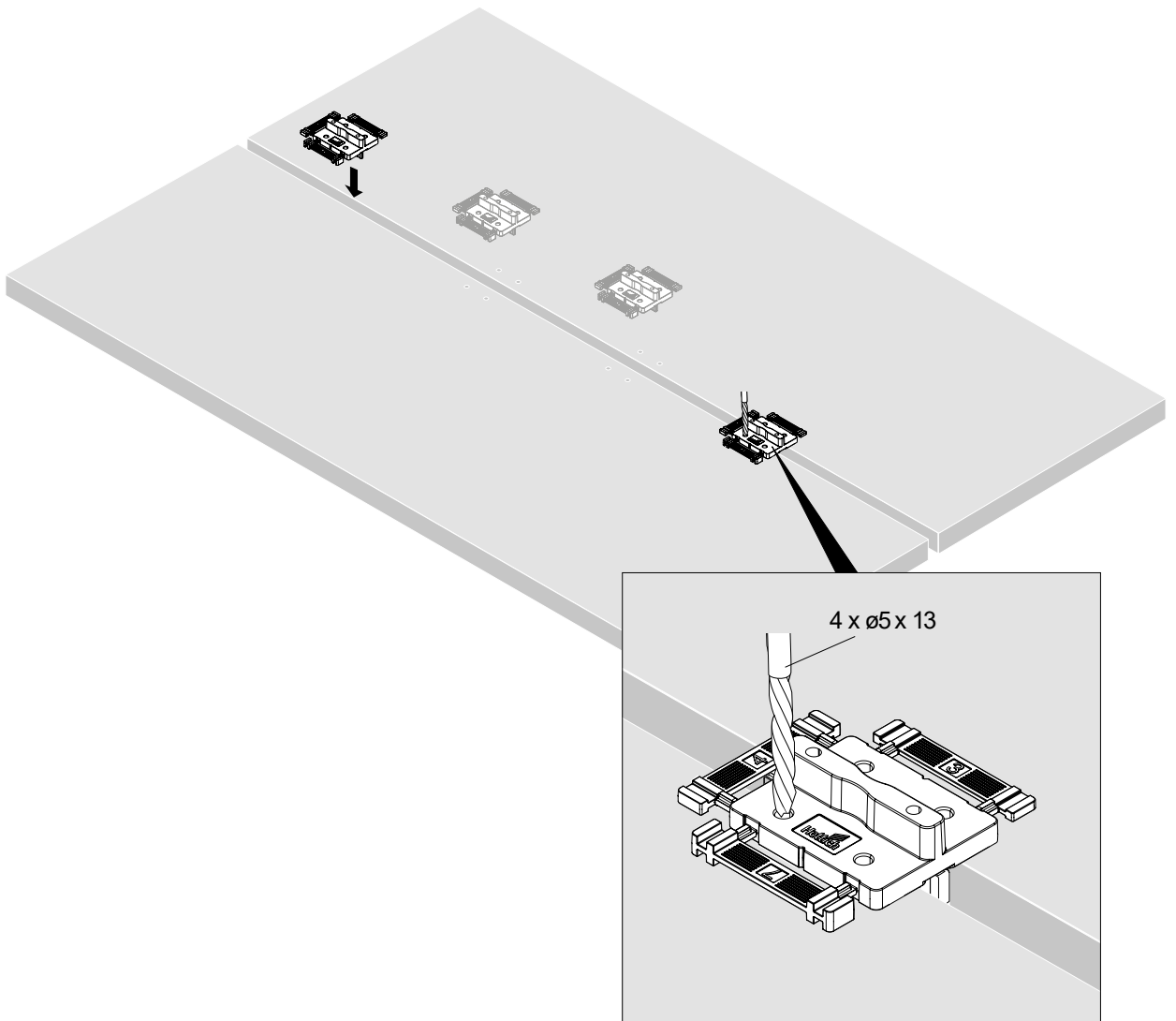
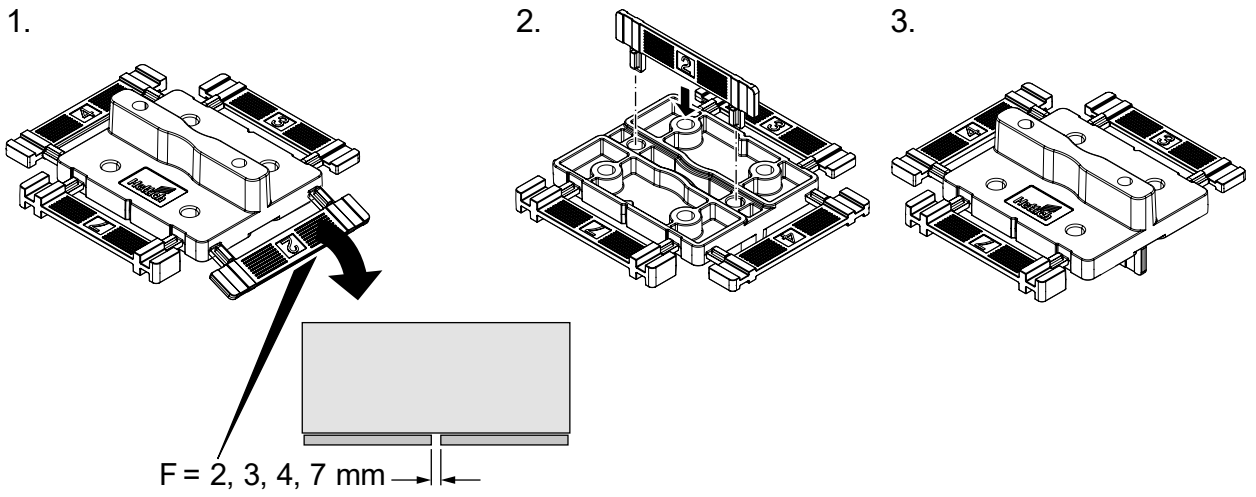
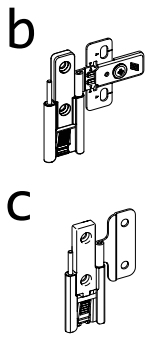



b

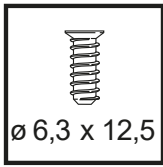
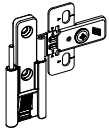

$\varnothing 6,3 \times 12,5$

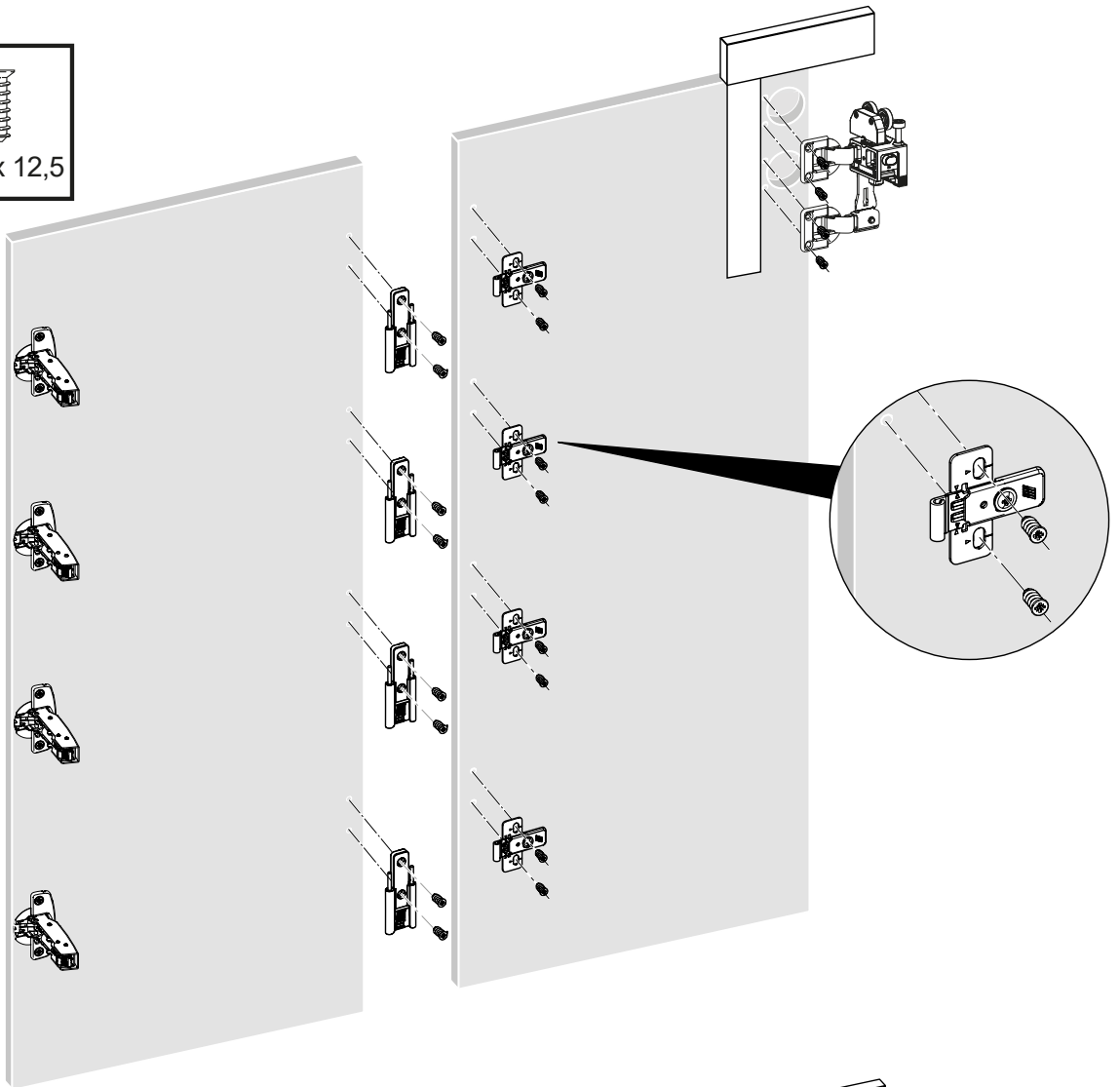

c

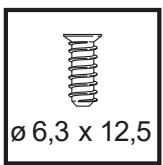
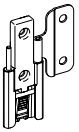

$\varnothing 6,3 \times 12,5$

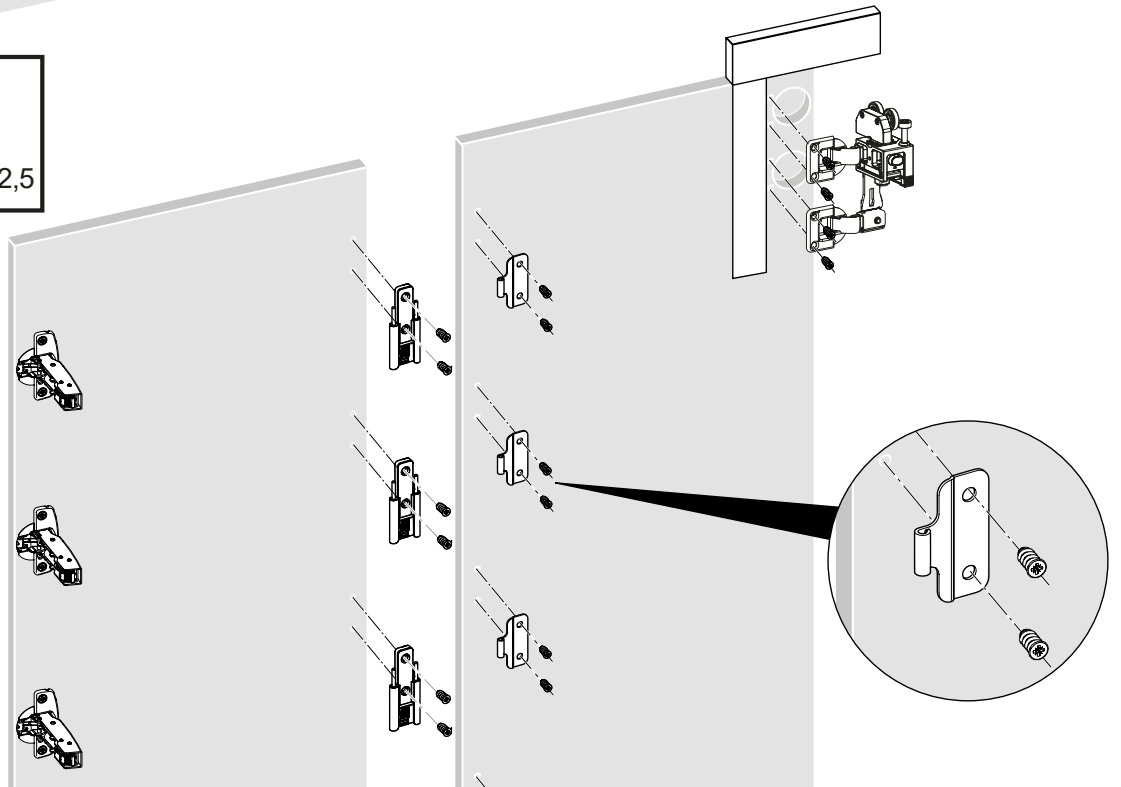

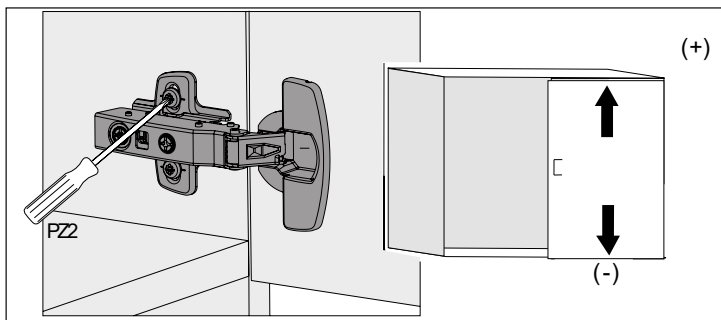
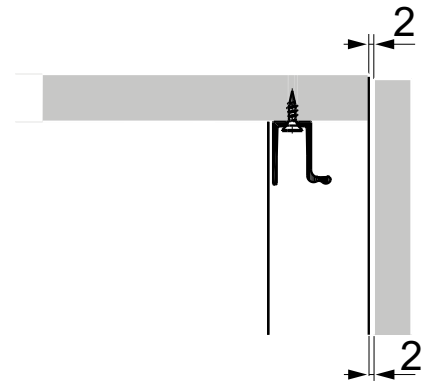
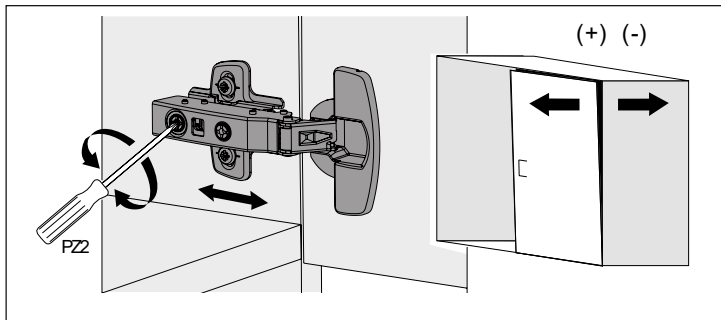
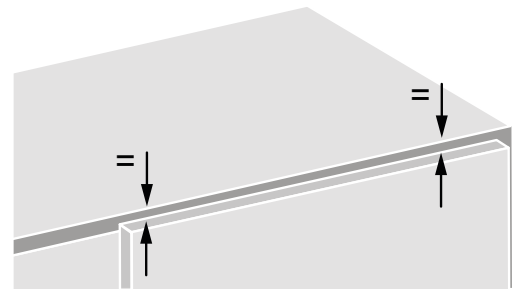
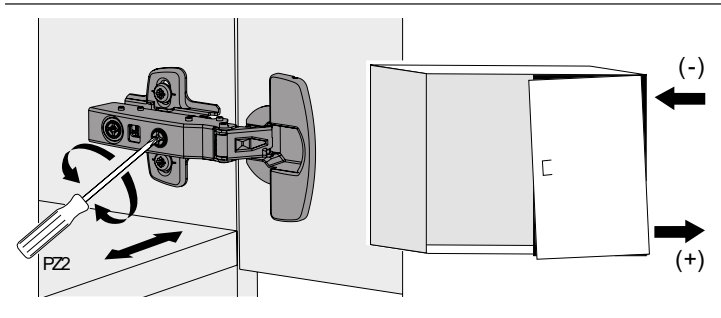
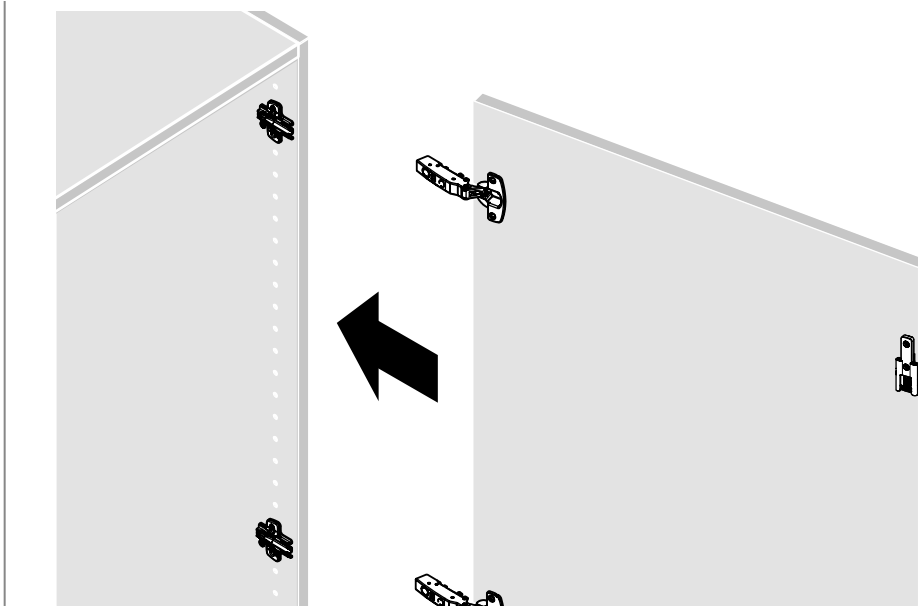
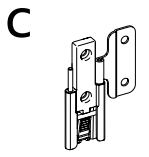
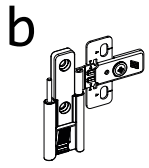

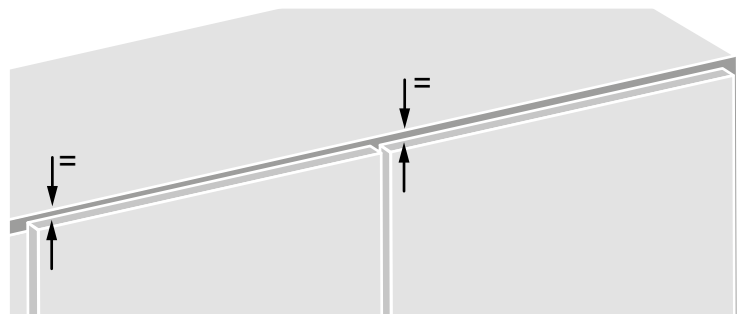
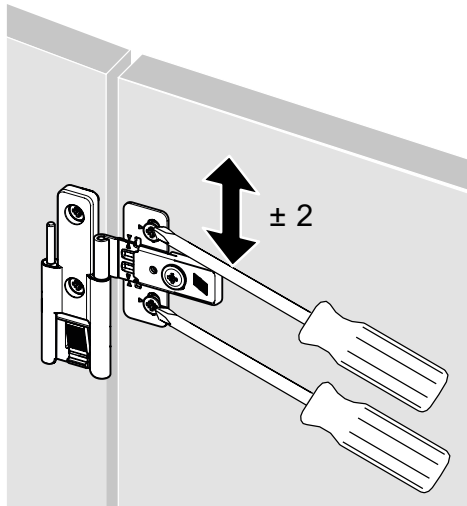
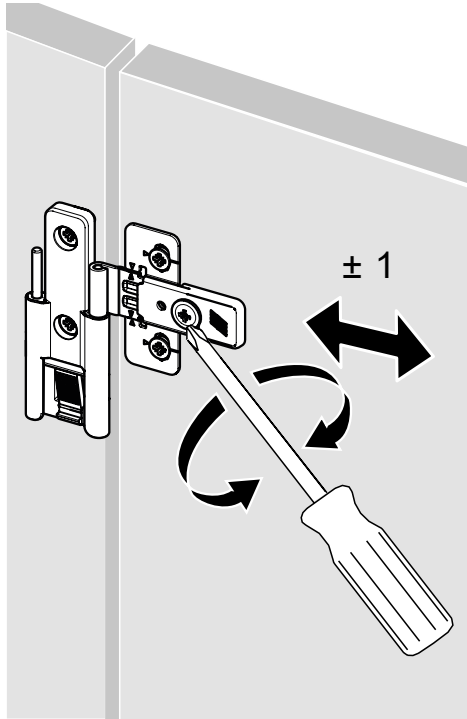
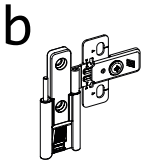
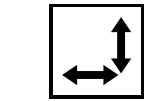
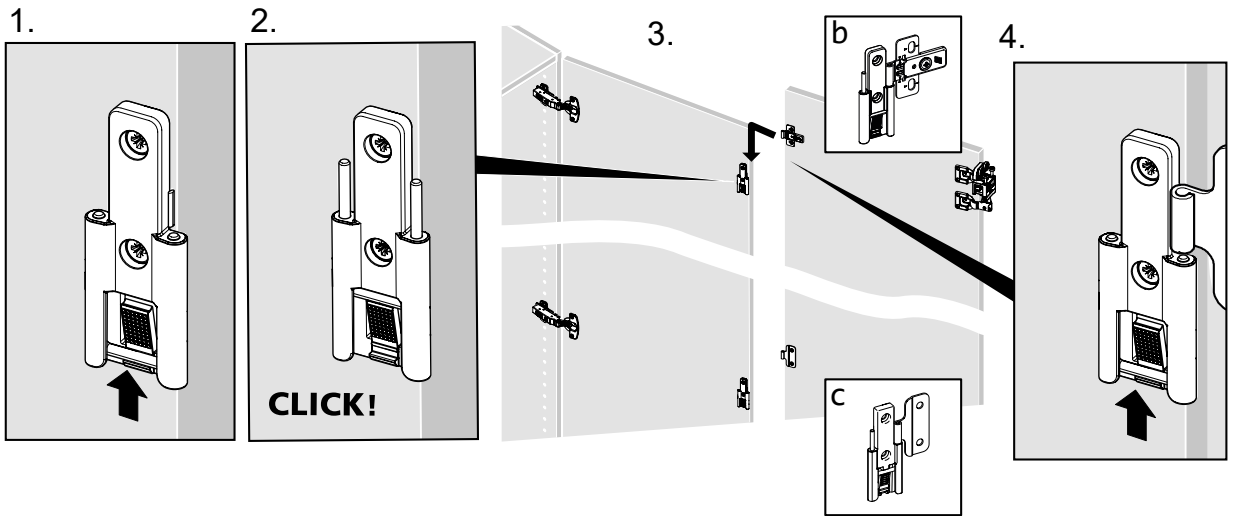
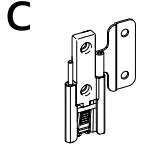
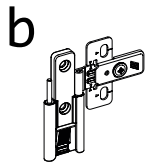

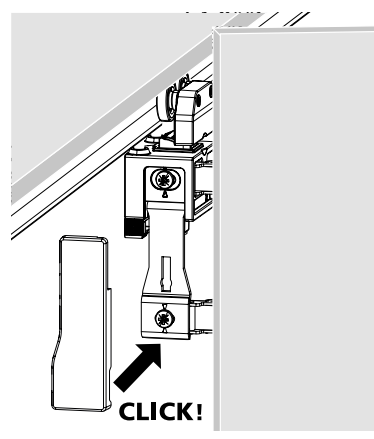
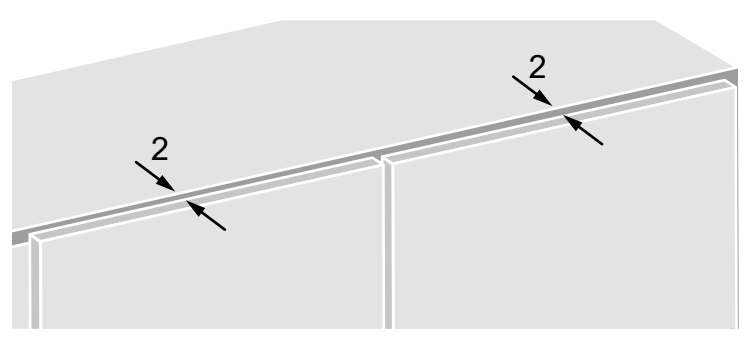
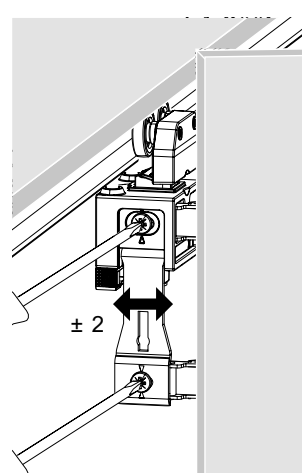
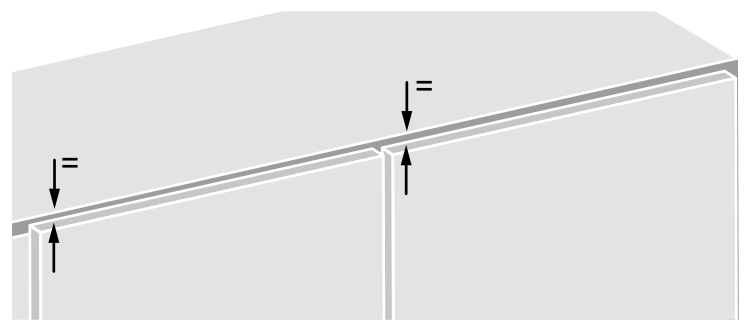
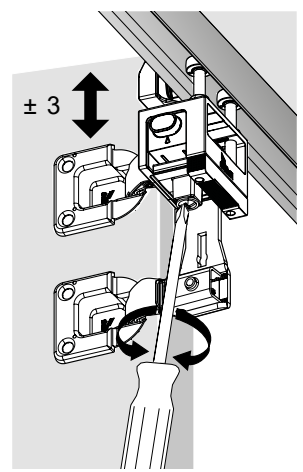
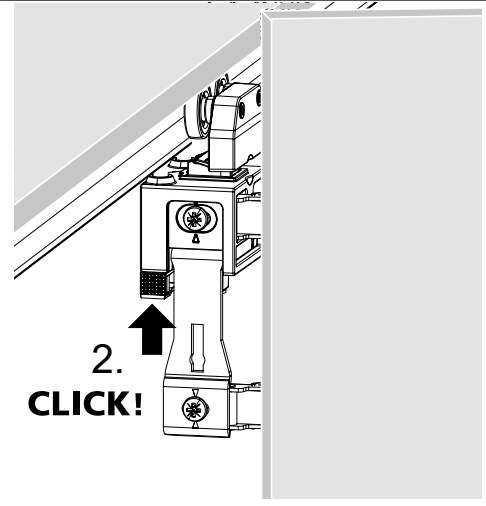
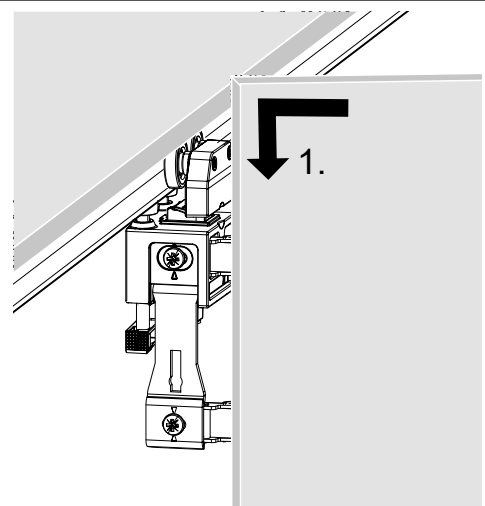
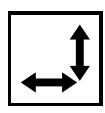
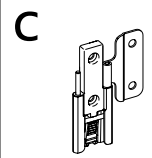
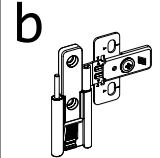
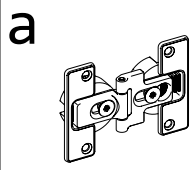



a

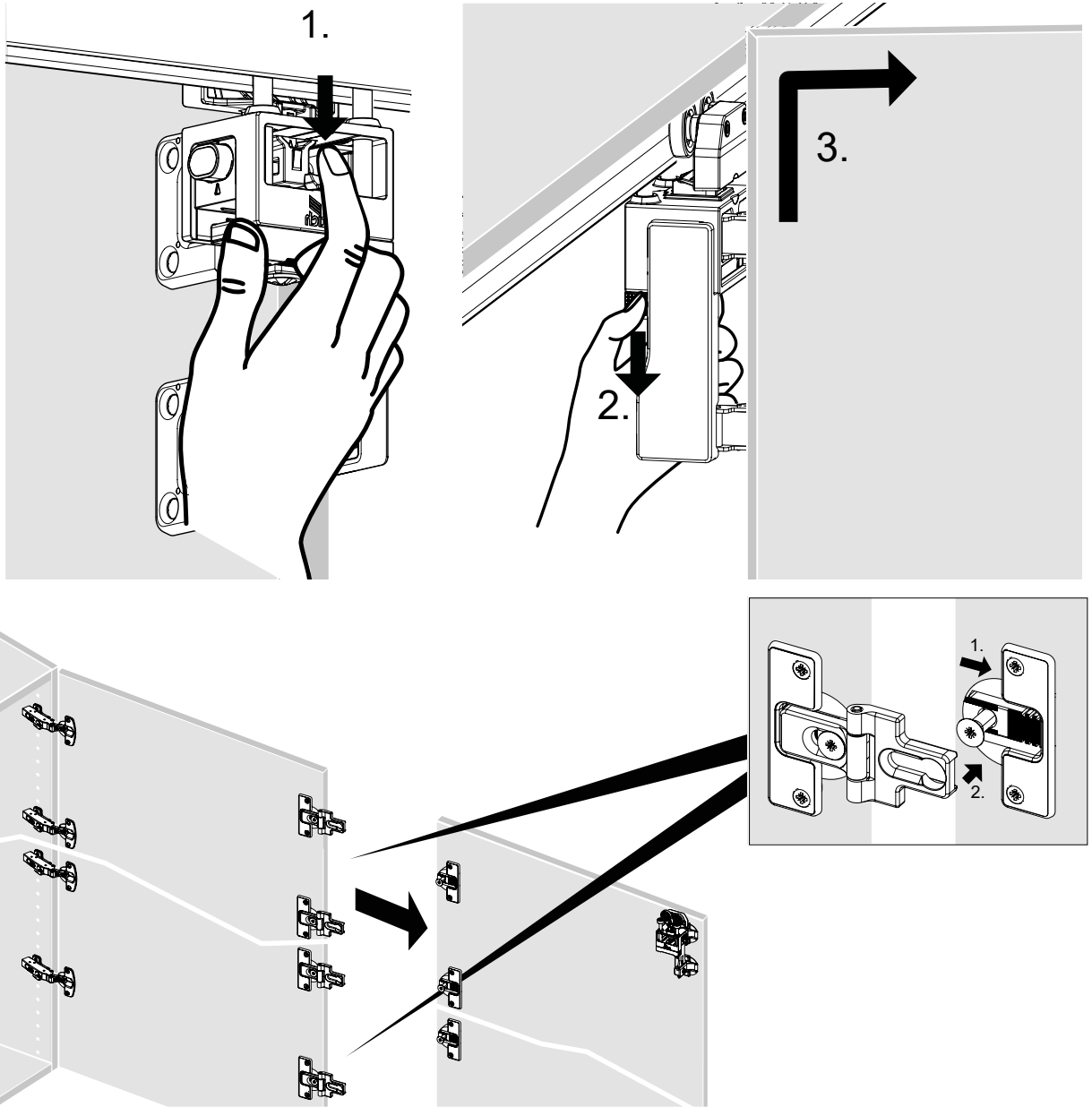



b

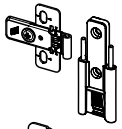

c

